



浙江经济职业技术学院

Challenges and reforms for the match with the social and economic development

Viewing TVET in China today from a practitioner angle

Expert consultation meeting
Bonn Germany
Jan 2009



Dean of OIRIA
Prof. Huang
Chunlin
(Chandler)





[Outline]

- 1 **Introduction**
- 2 **The fact of educational system in China**
- 3 **Hot issues and challenges in TVET China**
- 4 **Int'l cooperation and adoptions in TVET China**
- 5 **Trends and strategies in TVET China**
- 6 **UNESCO(UNEVOC) roles today and tomorrow in China**
- 7 **Conclusion**



1 Introduction

Achievements in Sci & Soc.

27-Sep Chinese astronauts made space walk

Beijing Olympic game 8-Aug to 24-Aug

Rapid development

Economic blooming

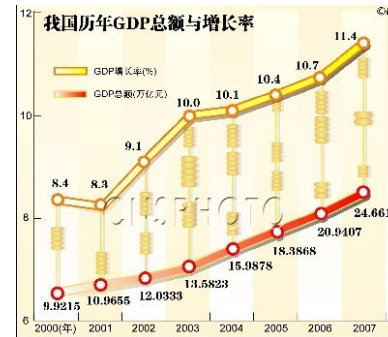

foreign exchange reserve





Challenges

Snowstorm

Earthquake

Unemployment **Financial crisis**



4-trillion-yuan budget
From the end of 2008 to 2010.
Driving domestic demand





40billion (1%)for medical cultural and educational development

“4万亿”投资结构

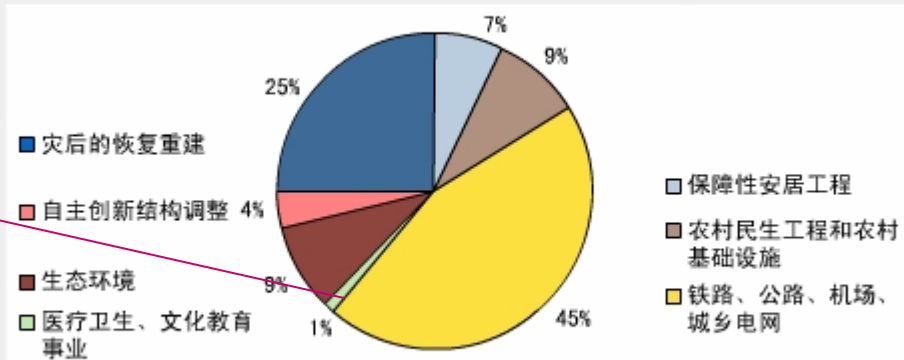

资料来源:国家发改委

1billion in 2008 fourth season for 366 projects in secondary vocational education

2008年四季度中央1200亿投资结构 (含200亿元灾后重建基金)

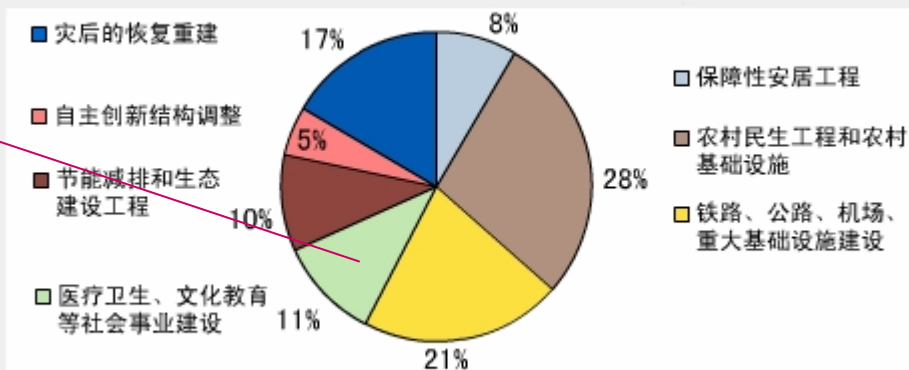

资料来源:国家发改委



浙江经济职业技术学院

● Urgent need of skilled labors

Only 33% skilled labors in the city laborforce of 14 million

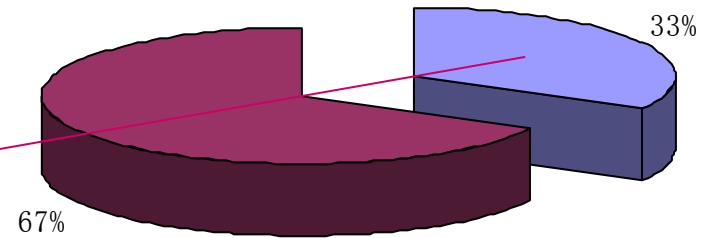

Proportion of skill levels from beginner to technician

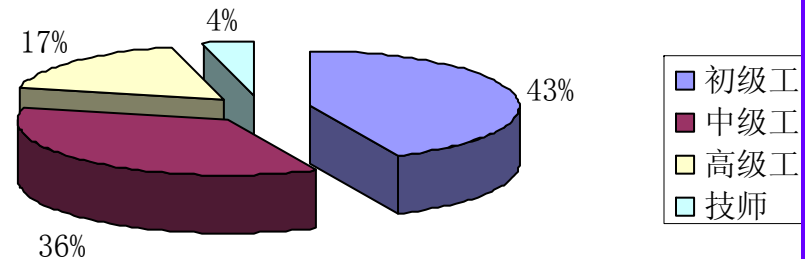



More than 87% labors of 40 million in rural area are under the middle school education

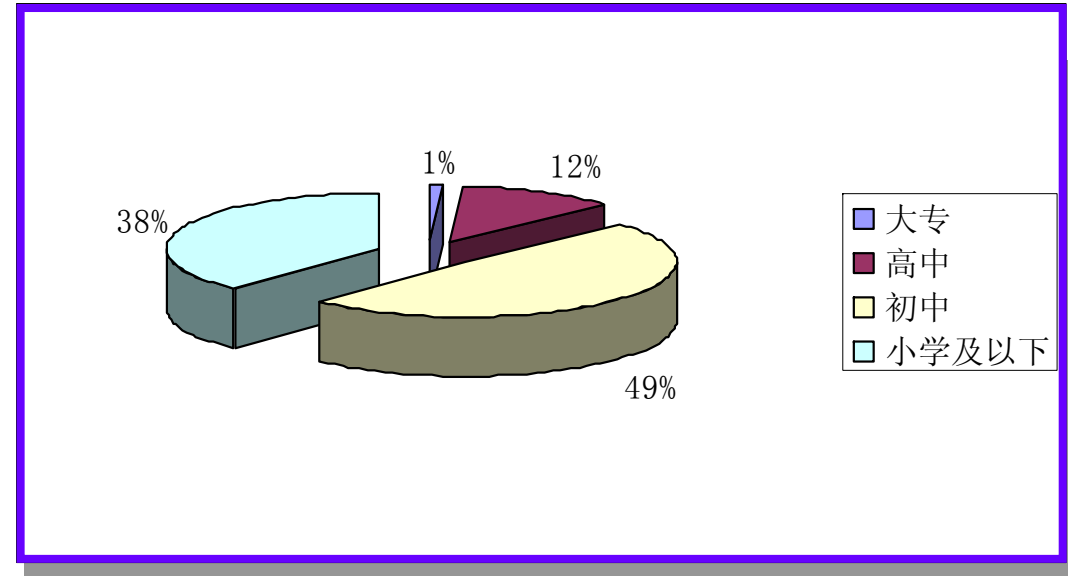

Skill equipped labors will be the key engine to the sustainable development in China



2 The fact of educational system in China



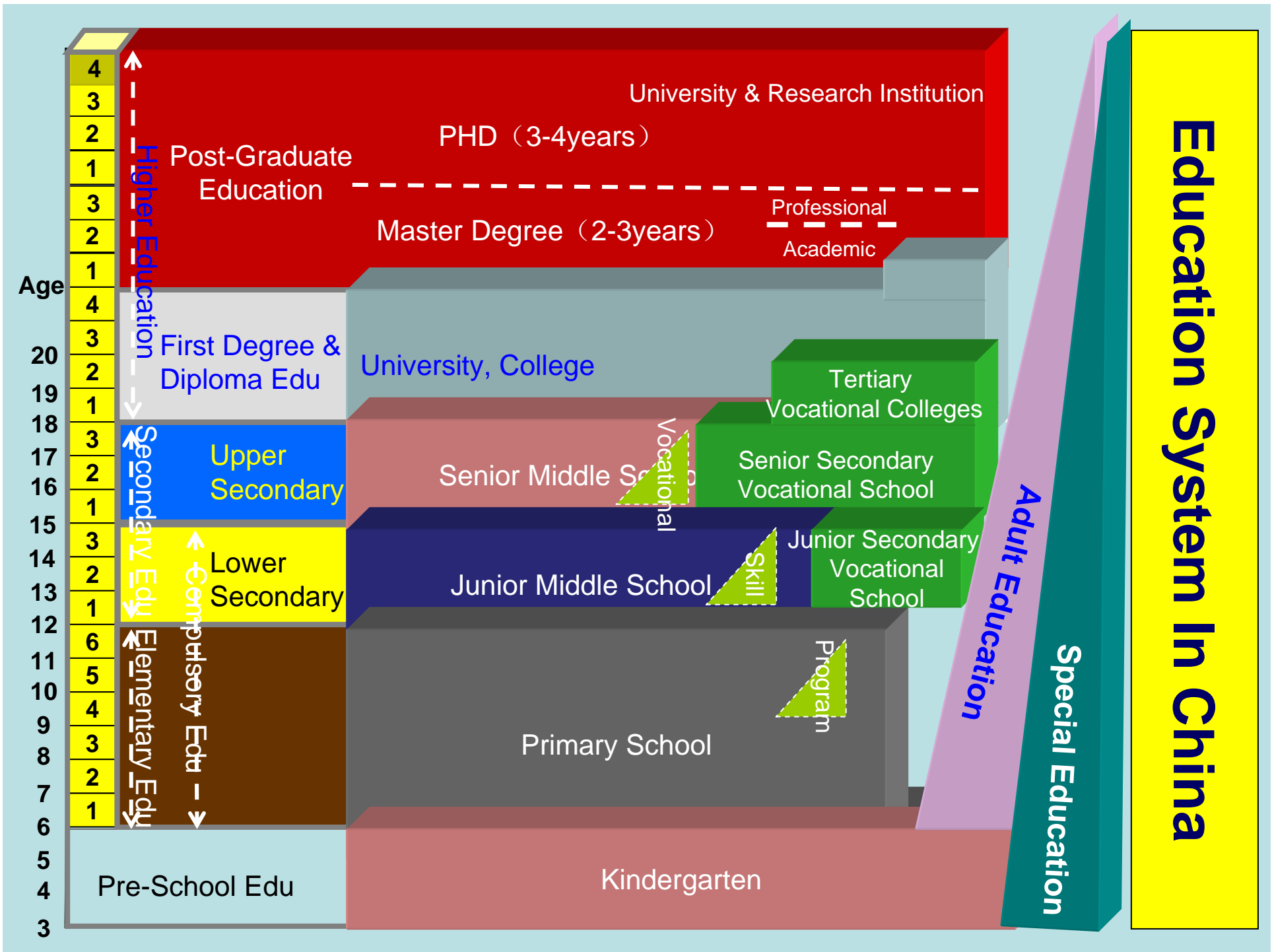



浙江经济职业技术学院

TVET in China

**Schooling
Vocational
Education**

**Non-Schooling
Technical
Training**

Schooling Vocational Education in Chinese Education System

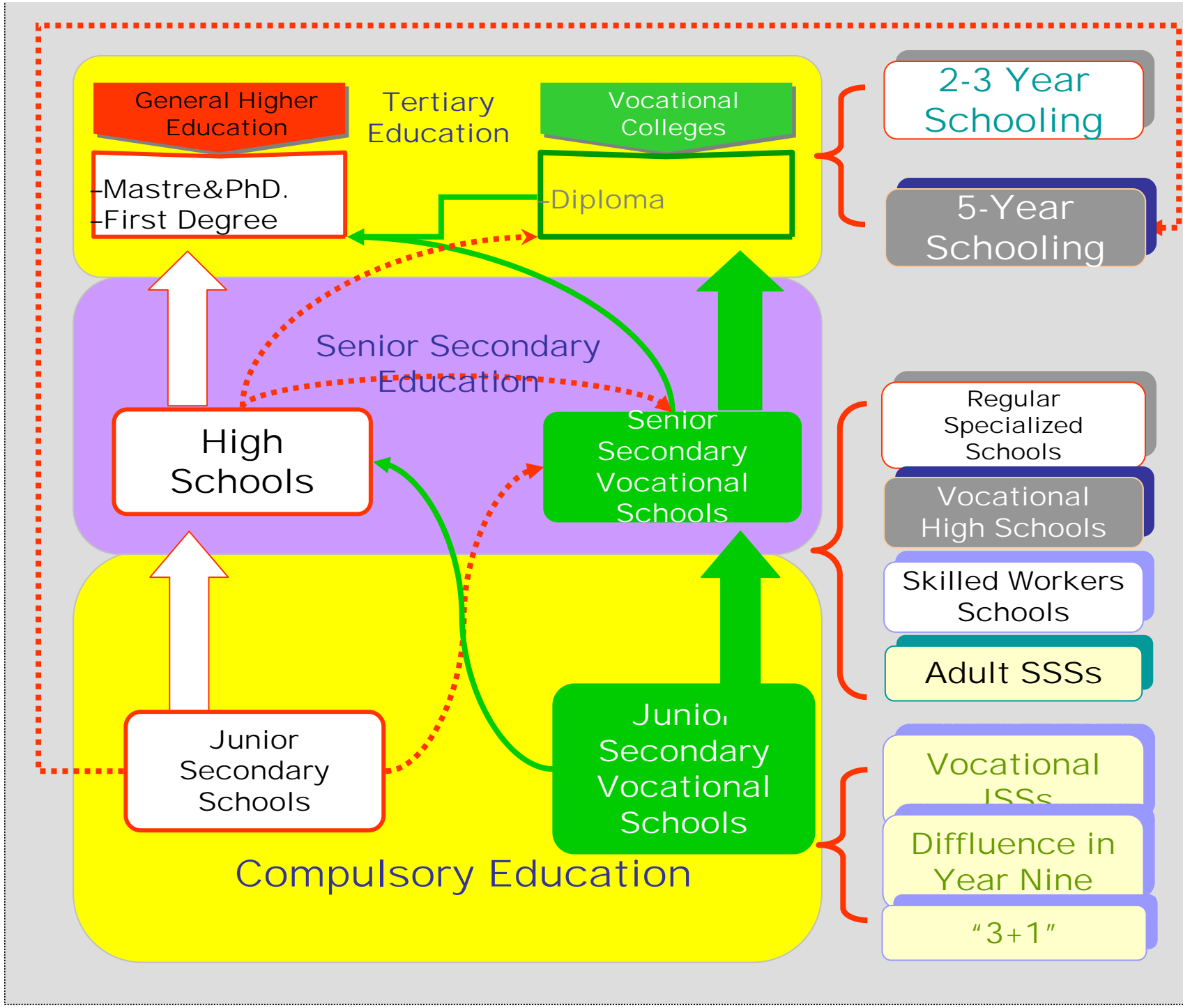

Technical & Vocational Training Framework in China

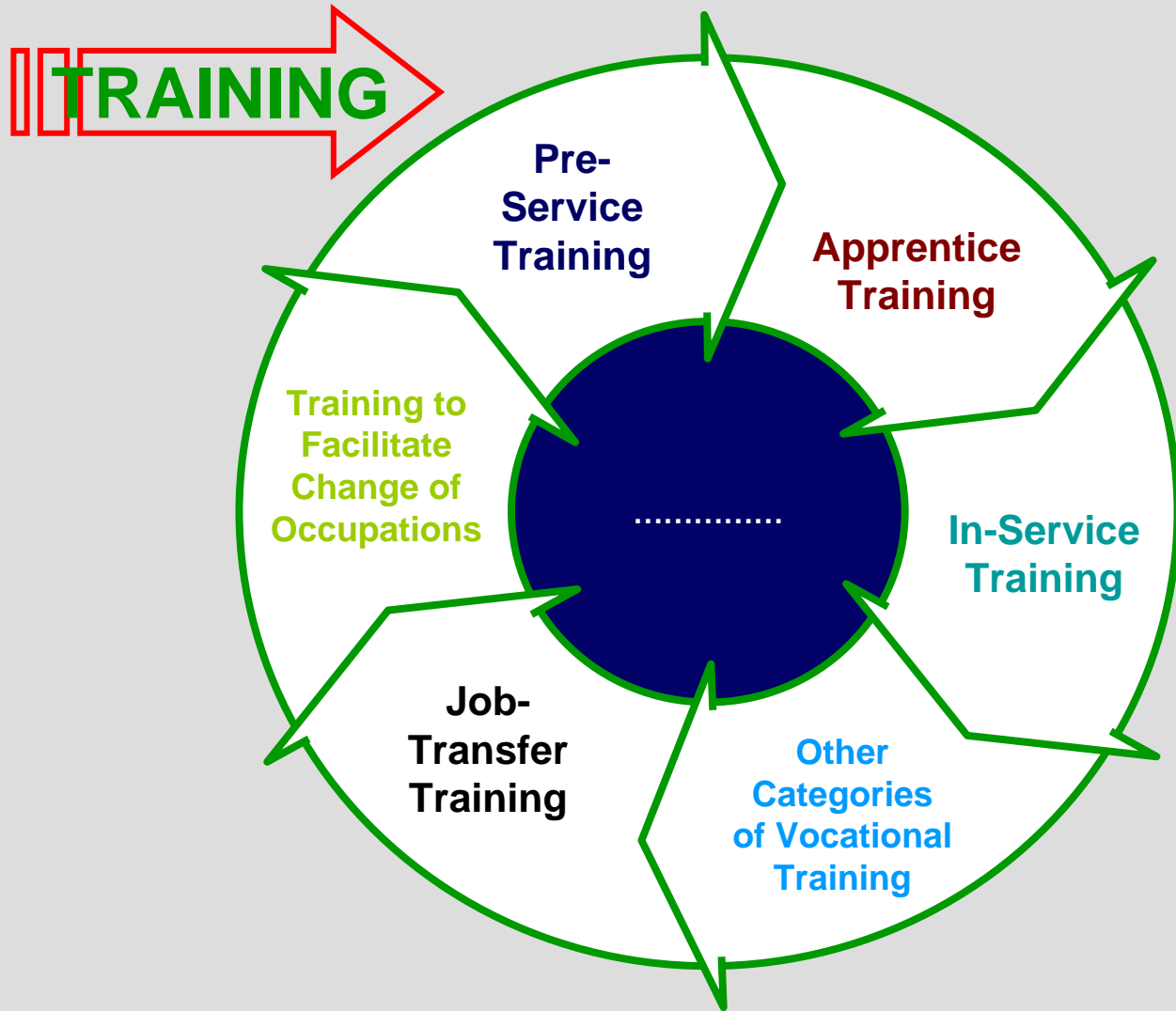

Two Types of Institutions: Vocational Schools, Training Establishments.

Three Levels: elementary, secondary and tertiary.



浙江经济职业技术学院

Schools between TVET and general education

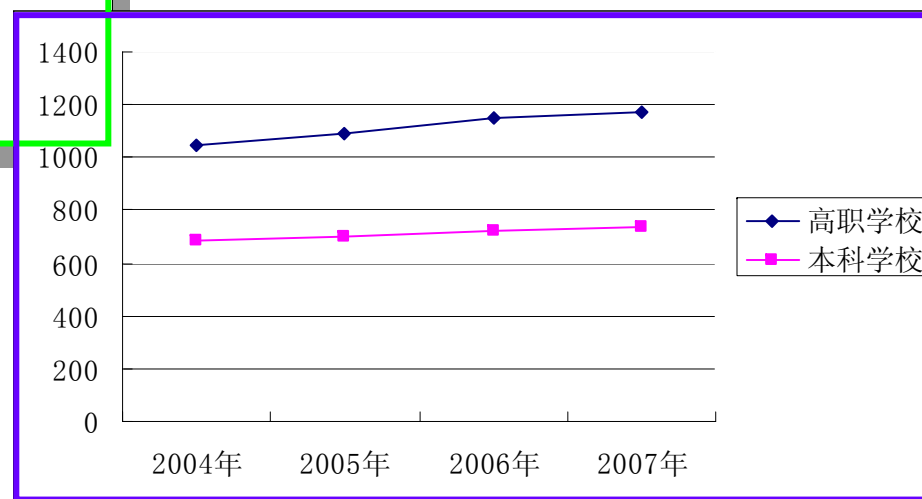
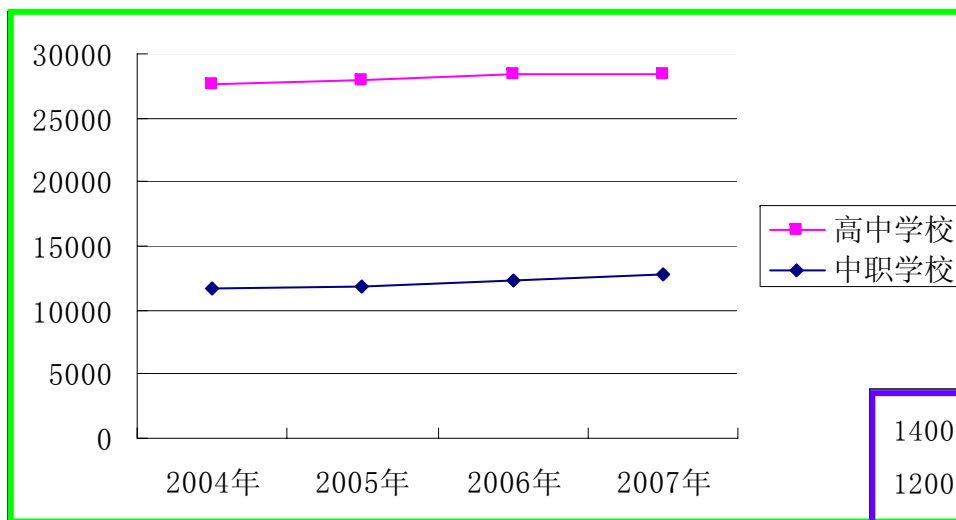



浙江经济职业技术学院

● First year students comparison

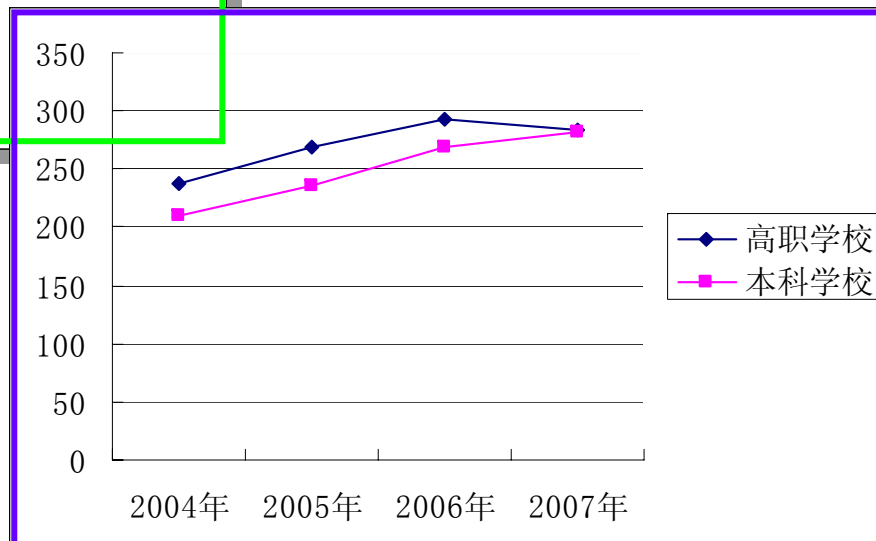
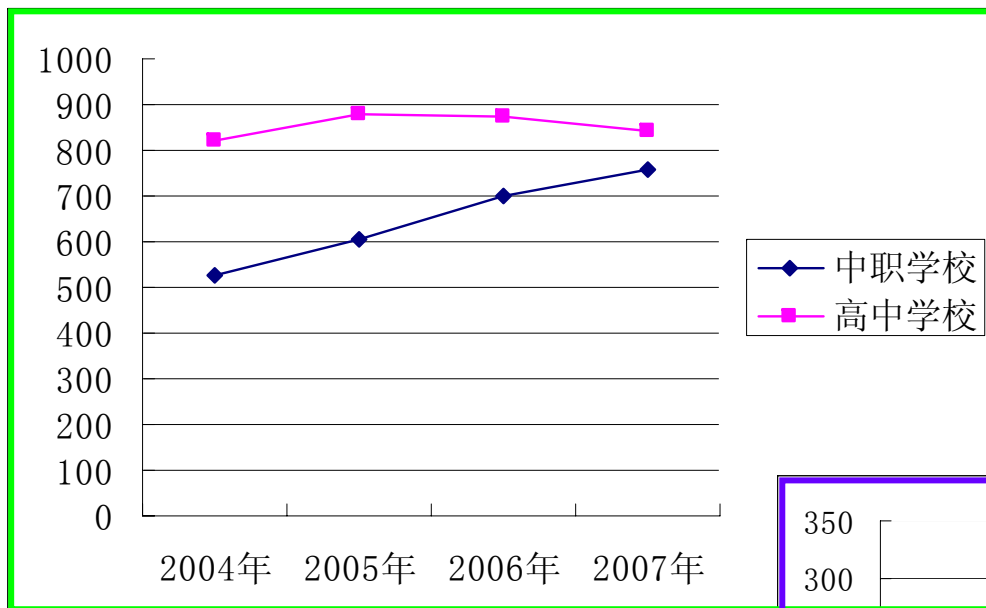



浙江经济职业技术学院

● On-the campus students comparison

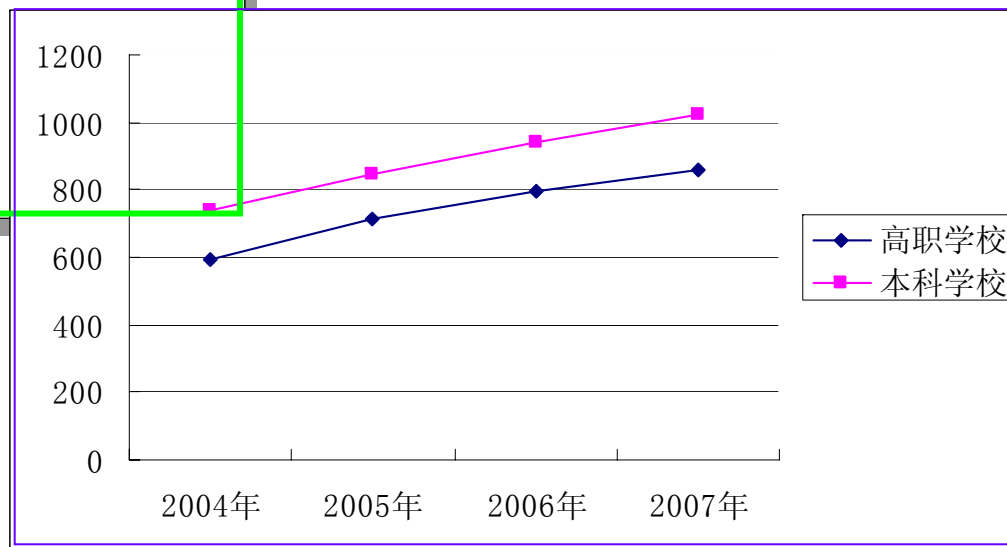
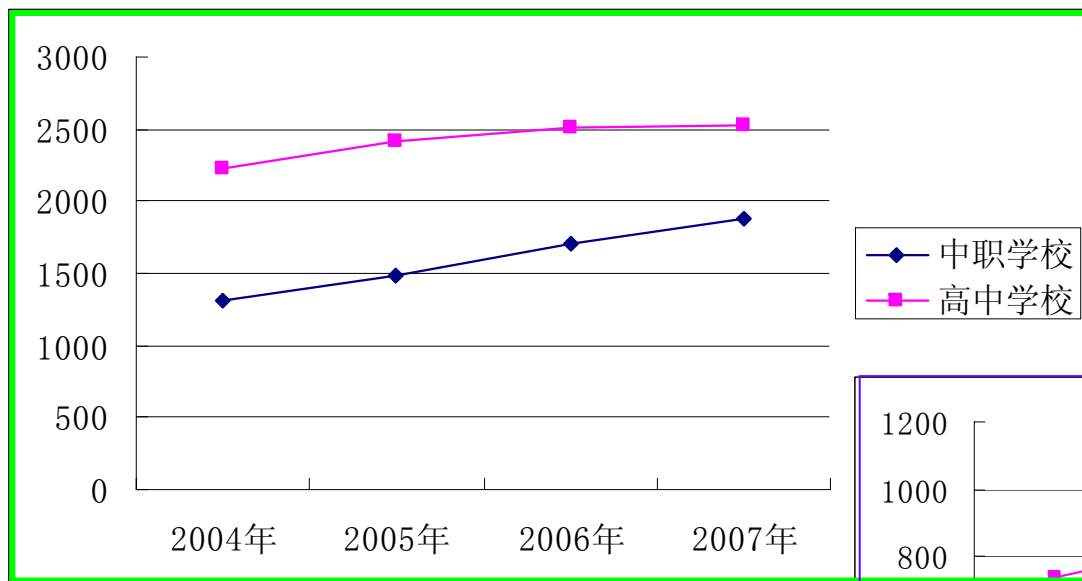



浙江经济职业技术学院

● Graduates comparison

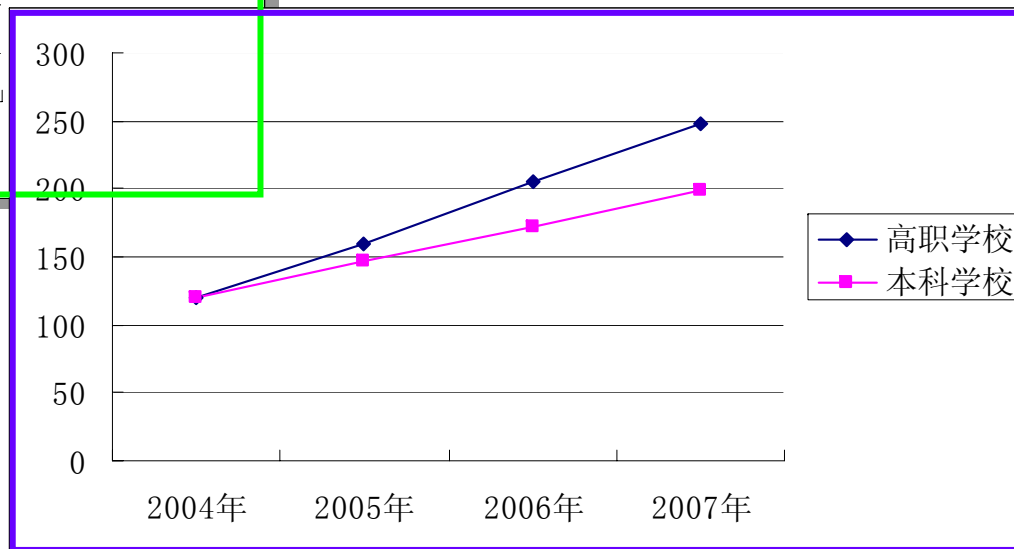
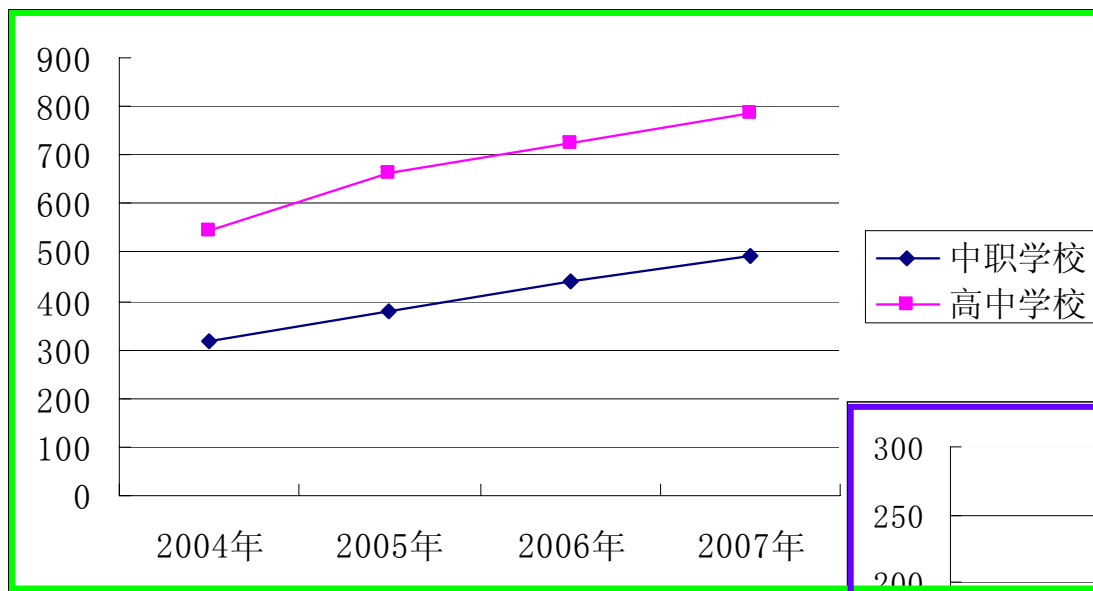



**TVET in China is of bigger proportion in
China's educational system**



3 Hot issues and challenges in TVET China

Keyword: motivation of industry involvement

1

Cooperative education between school and industry

Keyword: target work

2

Work process oriented teaching and learning

Keyword: practical experience

3

TVET Teacher education

Keyword: industry acknowledge

4

Job qualification

Keyword: diversified pattern

5

Institutional reform

Keyword: Academic autonomy

6

Governance and decentralization

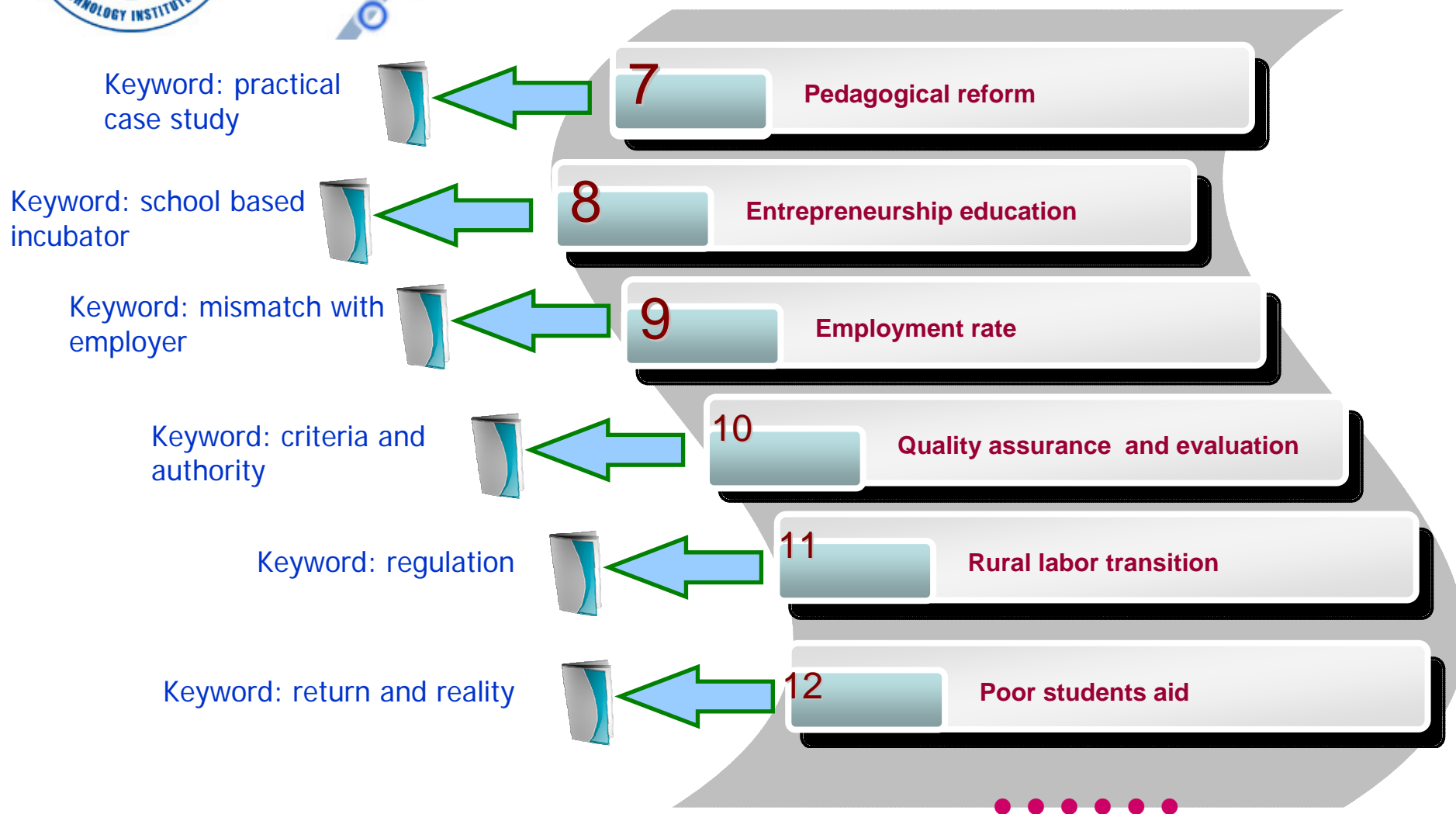



**Reform and Innovation, the major
themes of TVET in China**



4 Inter'l cooperation and adoptions in TVET China

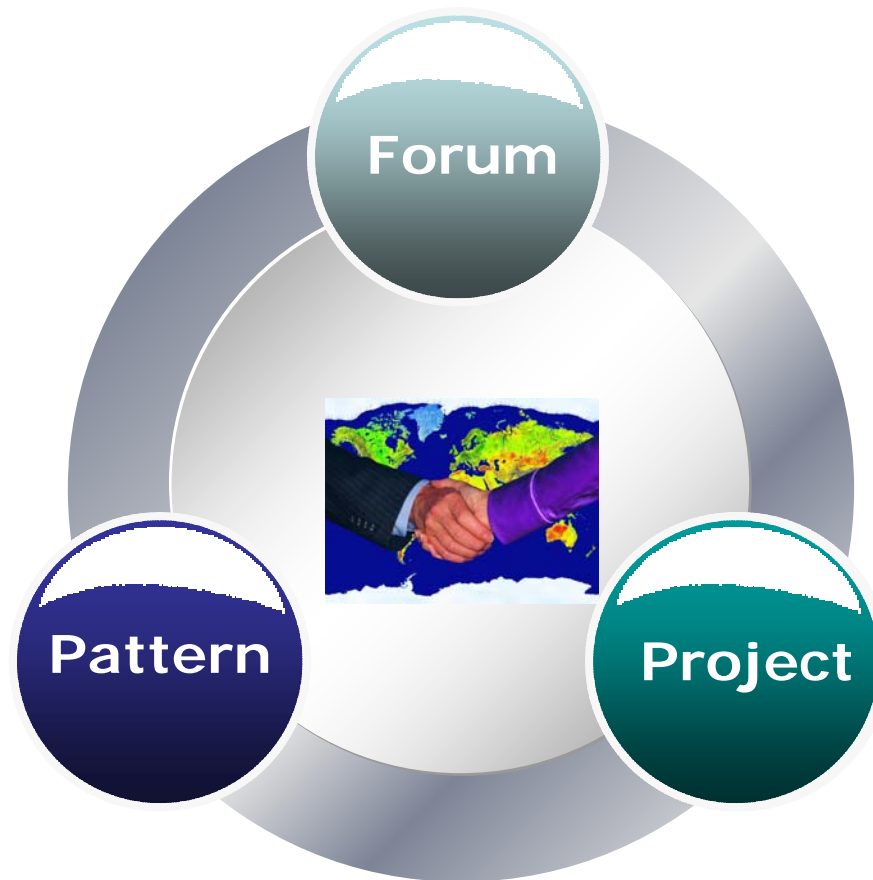

Learning from outside world

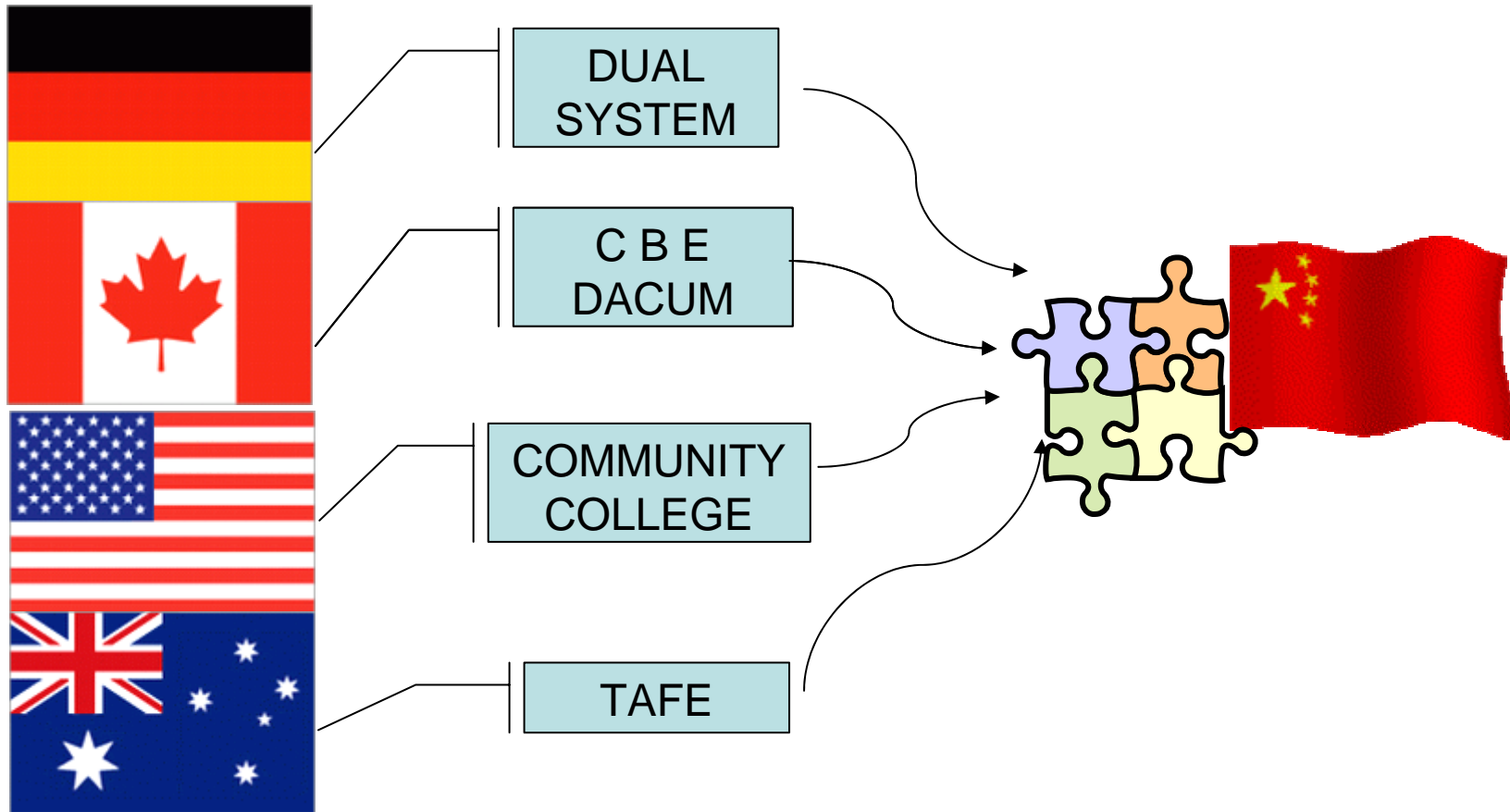



- Joint-project with overseas
- International conferences in China

**TVET in China is from adopting to
innovating toward exporting**



5 Trends and strategies in TVET China

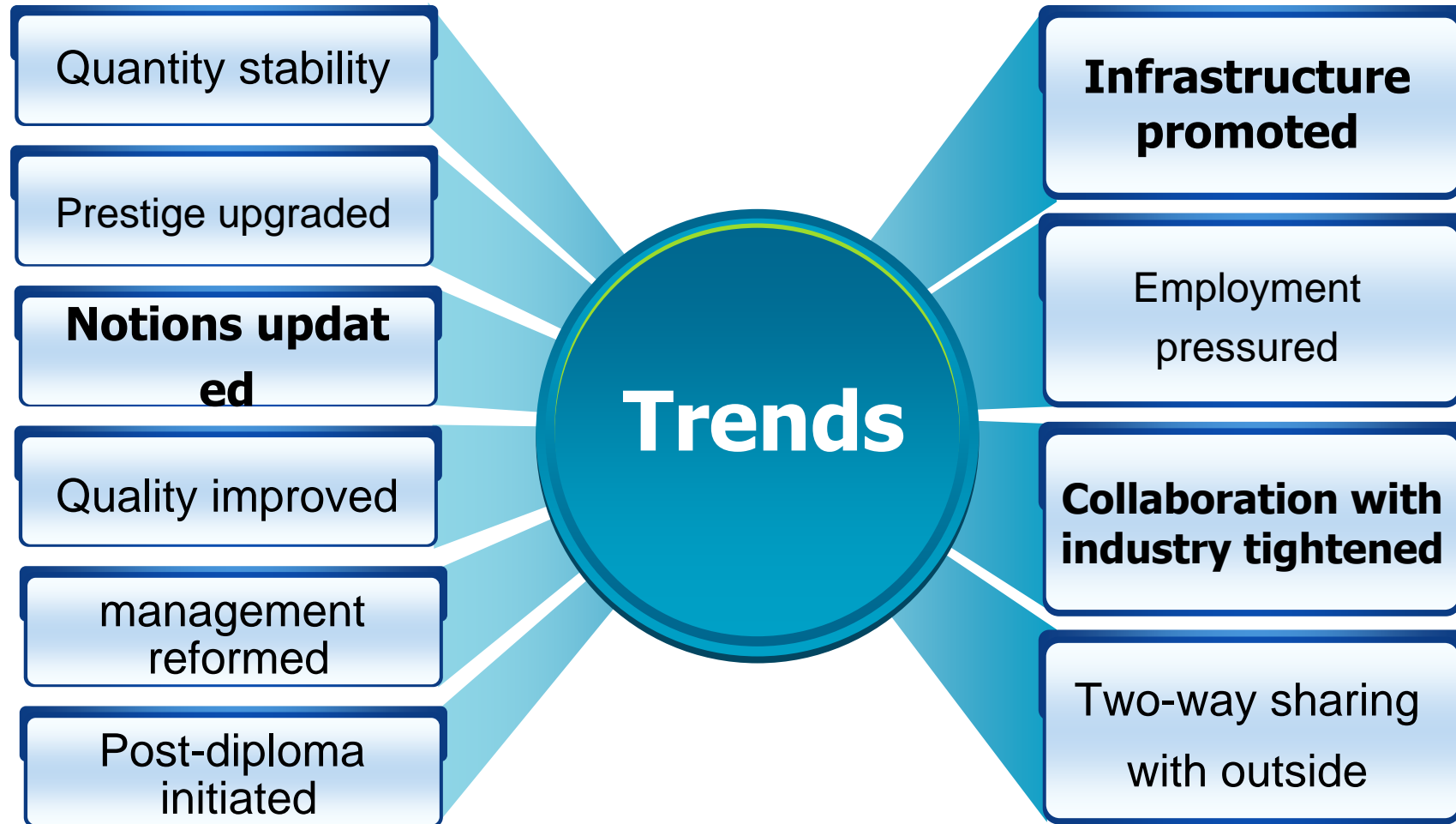



strategies

Infrastructure investment

Quality control

Cooperative education

Approach reform and innovation

**TVET in China is facing a great opportunity
to the further development**



6、 UNESCO(UNEVOC) roles today and tomorrow in China

INTERNATIONAL CENTRE
for Technical and Vocational
Education and Training

International Centre for Technical and Vocational Education and Training

Text Sitemap Search: OK Advanced Search English Français Español

UNEVOC.UNESCO.org

UNESCO-UNEVOC Directory

Results:

- [Beijing ChangPing Vocational School, China](#)
- [Beijing Municipal Supply and Marketing Institute, China](#)
- [Beijing Union University, China](#)
- [Central Institute for Vocational and Technical Education, Ministry of Education, China](#)
- [China Beijing Professional Teacher Training Centre of Chao Yang District, China](#)
- [College of Vocational and Technical Education, Tianjin University, China](#)
- [Handan Vocational and Technical College, China](#)
- [Henan Information Engineering College, China](#)
- [Shenzhen Polytechnic, China](#)
- [The Hong Kong Institute of Education, China](#)
- [Training Center for Teachers of Vocational Education of Shanghai Second Polytechnic University, China](#)
- [Zhejiang Technology Institute of Economy, China](#)

12 UNEVOC Centre/s found.

[back](#)

The Organization

- About UNESCO-UNEVOC
- Mission
- Staff
- Employment
- Contact

Communities

- UNEVOC Network
- e-Forum
- Foro hispano/luso
- TVET Institutions

Services

- Publications
- Information Services
- Login / Subscribe
- Donor Agencies Guide

Features

- Directory of UNEVOC Centres
- Participation in TVET Worldwide: A Statistical

China
12 centres

Log in
Get Involved



浙江经济职业技术学院

UNEVOC Centres in China

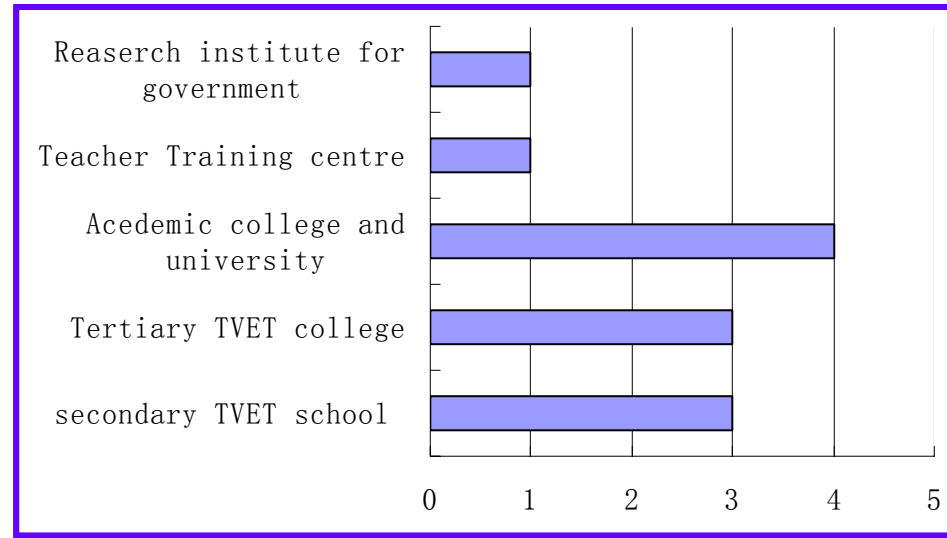

Most located in universities
Some of the 6 centres in TVET institutions are not very typical



Common awareness of concepts

Misunderstanding or simply thoughts
Problem of translation and different situation

Training projects for

- Policy maker-school managers
- Government officers
- Researchers
- Teachers

Experience sharing

- Conference regionally locally and internationally
- Materials exchanging
- Update issues research
- Successful alumni
- Recommend some great TVET educators and their works

Periodicals for TVET internationally

- English version first and then other languages

suggestions



Conclusion

- **Rapid development in China needs TVET to be sustainable development**
- **TVET in China is from adopting to innovating toward exporting**
- **UNESCO (UNEVOC) has been playing an important role and still have potential in developing TVET nationally and internationally**



浙江经济职业技术学院

Thank you for your attention!

Thank you for your attention!